

CROMPTON INSTRUMENTS
INTEGRA 2270
POWER QUALITY METER

INTEGRA 2270 POWER QUALITY METER

Power to analyse quality, with a touch

THE NEW INTEGRA 2270 POWER QUALITY METER MONITORS THE QUALITY OF INCOMING ELECTRICITY WITH A 0.25% ACCURACY OF READING

- **Total Harmonic Distortion** - the total distortion in the supply, measured as harmonics of the base frequency up to the 63rd harmonic.
- **Waveform Capture** - allows instantaneous events to be captured and analysed offline using a computer.
- **Voltage Interference** - known as 'sags and swells'. Variations in the voltage supply caused by non-linear loads, as described BS EN 50160:2010.



Key features

Full colour touch screen display

Energy-efficient and intuitive touch screen display with clear graphics and simple navigation. Easy for Field Engineers to set up and configure, reducing site time and saving money during installation.



Easy installation

Plug and socket connectivity for easy installation of prewired looms, saving valuable installation time and reducing wiring errors. **Current flows directly through the meter primary CTs**, meaning there is no need to terminate the CT wire at the meter.



Signal conditioning

Patented* technology enables measurement of power quality within any voltage of electrical supply, in a single product, covering the global range 120/230V of electrical supplies.

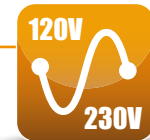

Inputs and output

- Total measurement for all utilities in a single meter, including measurement of **pulses from water and gas meters**.
- Can be configured to communicate outputs relating to active and reactive energy to building management systems
- **Alarms** can be configured for any relevant, measured parameters and can also serve as a trip function



*Patent pending

See Page 3 for Product Code (Full Part Numbers)

CROMPTON INSTRUMENTS INTEGRA 2270 POWER QUALITY METER



**Power to
analyse quality,
with a touch**



The Integra 2270 digital meter provides measurement, isolation and conversion of all main electrical parameters and can be used in single-phase and three-phase three-wire unbalanced, four-wire balanced and unbalanced systems. RS485 Modbus RTU communications protocol, pulse/alarm outputs and inputs are fitted as standard.

Standards

EMC	IEC 61000-4-2 IEC 61000-4-3 IEC 61000-4-4 IEC 61000-4-5 IEC 61000-4-6 IEC 61000-4-8 IEC 61000-4-11 IEC 61326-1, Class A IEC 61000-3-2 IEC 61000-3-3
Safety	IEC 61010-1
Accuracy and Measurement	IEC 62053-21 class IEC 62053-22 class 0.2S IEC 62053-23 class 0.5S ANSI C12.20
Features	IEC 50160 (sag/swells classes) EN60688 ANSI C37.90.1 (surge withstand) ANSI C62.41 (Burst) RoHS compliant

Product Codes

Description	Part number
Integra 2270	INT-2270-M-01
Integra 2170	INT-2170-M-01

Approvals:
CE

Features (INT-2270 only)

- Waveform capture 8 cycles per phase
- Sags/swells monitoring to BS EN 50160
- Accuracy to 0.25% (reading)

Features (all products)

- Full colour, energy efficient, touch screen user interface
- Patent pending signal conditioning technology
- Fits both ANSI and DIN cut-outs
- Alarm/pulsed output
- Pulsed inputs
- User programmable configuration
- Heart beat indication for self checking
- Min/Max value stored in non-volatile memory
- Individual harmonics measurement to 63rd harmonic
- Active power (kW) by phase
- Reactive power (kVAr) per phase
- Apparent power (kVA) per phase
- Current demand (AD) per phase
- Unbalanced voltage (%)
- Unbalanced current (%)
- Internal temperature measurement
- Hours run
- Supported real time clock
- Soft alarms
- Percentage of load bar for full scale indication
- User programmable display screen
- Accuracy to 0.5% (reading)
- Sub cycle transient monitoring

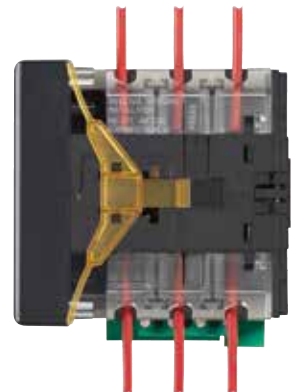

Specifications

Input	
Nominal input voltage:	57.7V - 346V AC L-N (100 -600V L-L) 720V MAX
Max. continuous input overload voltage:	120% of nominal
Max. continuous input overload voltage:	2 x nominal voltage for 1 second
Nominal input voltage burden:	<0.5VA per phase
Nominal input current:	1A AC or 5A AC RMS
Nom. Input current burden:	<0.1VA
Max. continuous input overload current:	120% of nominal
Max. continuous input overload current:	20 x nominal current for 1 second

Auxiliary	
Operating range:	110-250V AC/DC (+/- 20%) 45-66Hz (88-300V AC absolute limit)
Supply burden:	10VA

Accuracy	
Voltage (V):	0.18% of reading + 0.02% nominal
Current (A):	0.18% of reading + 0.02% nominal
Neutral current calculated (A):	< 1.0%
Frequency (Hz):	< 0.1 Hz
Power factor (PF):	± 1% of unity
Active power (W):	± 0.25% of reading (at unity power factor)
Reactive power (VAR):	± 0.25% of reading (at unity power factor)
Apparent power (VA):	± 0.25% of reading (at unity power factor)
Active energy (kWh):	Class 0.2S (IEC 62053-22)
Reactive energy (kVARh):	Class 0.5S (IEC 62053-23)
THD:	1%

Range	
Voltage (V):	20% to 120% of nominal
Current (A):	1% to 120% of nominal
Frequency:	45-66 Hz
Power factor:	1 .. 0 lead or lag, 4 quadrant
Active power:	5 to 144% of nominal
Demand interval:	8, 10, 15, 20, 30, 60
THD:	up to 63rd harmonic
Energy:	8 digit displayed in Wh, kWh, MWh (Maximum 9,999,999.9 MWh before rollover to 0.0)

Environment	
Operating temperature:	-20°C to +60°C
Storage temperature:	-30°C to +80°C
Relative humidity:	0-95% non-condensing
Shock:	30g in 3 planes to IEC60068-2-6, 2g
Vibration:	10Hz to 50Hz, IEC 60068-2-6, 2g
Dielectric voltage:	Withstand test 2.5kV, 50Hz for 1 minute between auxiliary/input/output
IP protection (IEC 60529):	IP 52 front display IP 30 product
Altitude:	Up to 2000m
Installation category:	CAT III
Protection class:	II
Input waveform:	Sinusoidal (distortion factor < 0.005)
Magnetic field of external origin:	Terrestrial flux
Max wire gauge (input voltage, supply, I/O):	AWG 12/2.5mm ²
Max wire gauge (current pass through):	0.177"/4.5mm

Display

Size:	3.5" diagonal, 70mm x 52.5 mm
Resolution:	320 x 240 RGB
Colours:	16M
Type:	Touch screen (TFT)

Outputs Pulsed	
Pulse/alarm output relay (KYZ):	User defined solid state relay
Contact rating:	50mA max at 250VAC
Isolation:	2.5 kV RMS
Pulse duration:	60, 100, 200 msec
Pulse rate divisor range:	1 pulse per Wh up to 1 pulse per GWh
Pulsed output parameter:	Import/export kWh/kVArh
Energy units:	Kilo, mega, giga
Max pulse rate:	2 pulses per second

Outputs (Alarm)	
Alarm trip and release:	Any value in range
Alarm type:	User defined solid state relay, latched and unlatched
Alarm delay:	0 - 600 second
Delay resolution	10ms

Modbus™ Protocol	
Communication protocol:	RS485 Modbus RTU
Type:	2-wire half duplex
Baud rate:	2900, 4800, 9600, 19200, 38400

Inputs	
Number of digital (pulsed) inputs:	2
Voltage rating:	Logic high threshold > 2 volts Logic low threshold < 1.2 volts
Current rating:	Logic high threshold > 0.5 mAmps Logic low threshold < 0.1 mAmps
Max voltage limit:	30 volts
Max frequency:	25 Hz
Isolation:	2.5 kV RMS
Detection:	Rising, falling or both edges

Soft Alarms	
Number of soft alarms:	6
Alarm parameter:	Any practical Modbus parameter
Alarm trip level:	Any value in range
Alarm release level:	Any value in range
Delay:	0 to 600 seconds (10 minutes)
Output:	Latched/unlatched

Other Features	
Internal temperature measurement:	-20° C to +60° C
Internal temperature accuracy:	± 2° C
Under/over/critical temp:	User defined
Real time clock:	± 2 seconds per day (1 sec intervals)
Simultaneous waveform recording:	8 cycles of each phase (volts and amps)
Sub-cycle transients:	Voltage and current
Resolution:	0.15 ms



Dimensions

- 100 x 70 x 118mm
- 3.94" x 3.11" x 4.65"
- Weight 0.42kg
- 92mm square DIN cut-out
- ANSI C39.1, 4" round

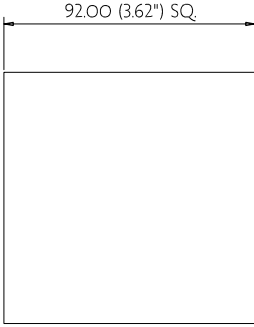

DIN CUTOUT

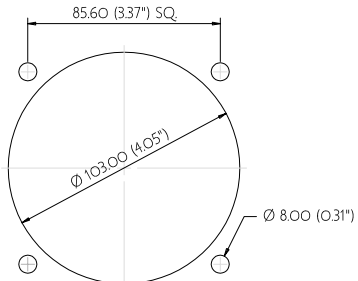

ANSI CUTOUT

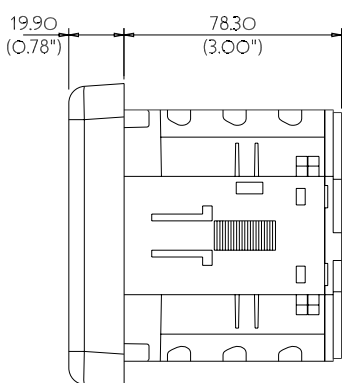
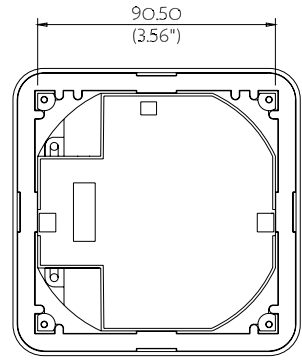
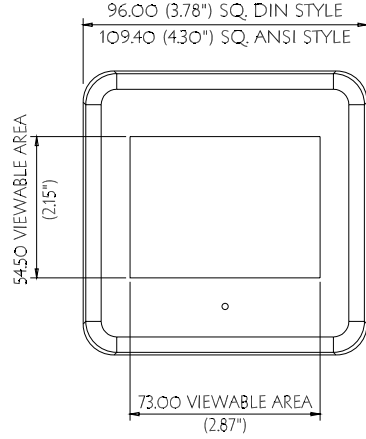

Connection Diagrams

3-phase 4-wire unbalanced

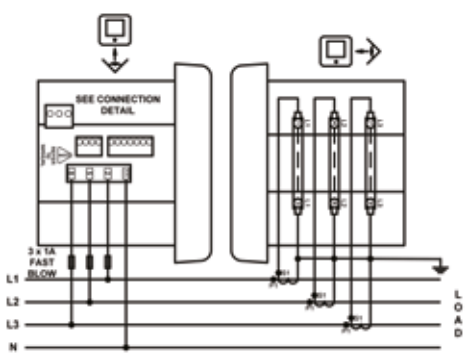

3-phase 3-wire unbalanced

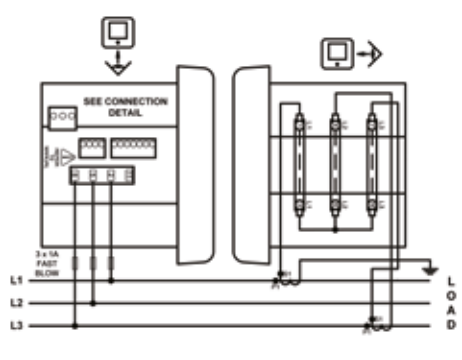

1-phase 2-wire

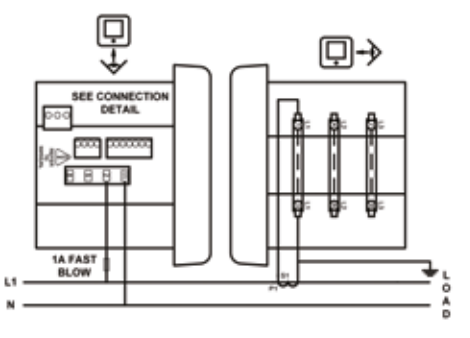

1-phase 3-wire

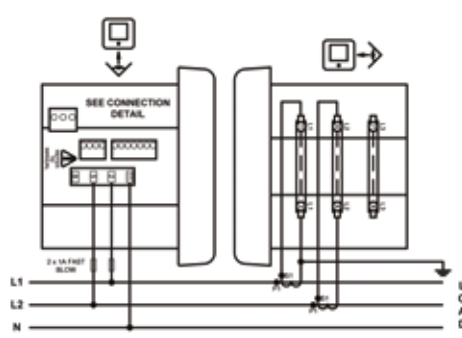

Connection Detail

